

# pompetravaini

(Rev. 2.0\_10-2010)



# DISASSEMBLY AND ASSEMBLY INSTRUCTIONS FOR MAGNETIC DRIVE MULTISTAGE SELF-PRIMING CENTRIFUGAL PUMPS

## TBK - TBAK

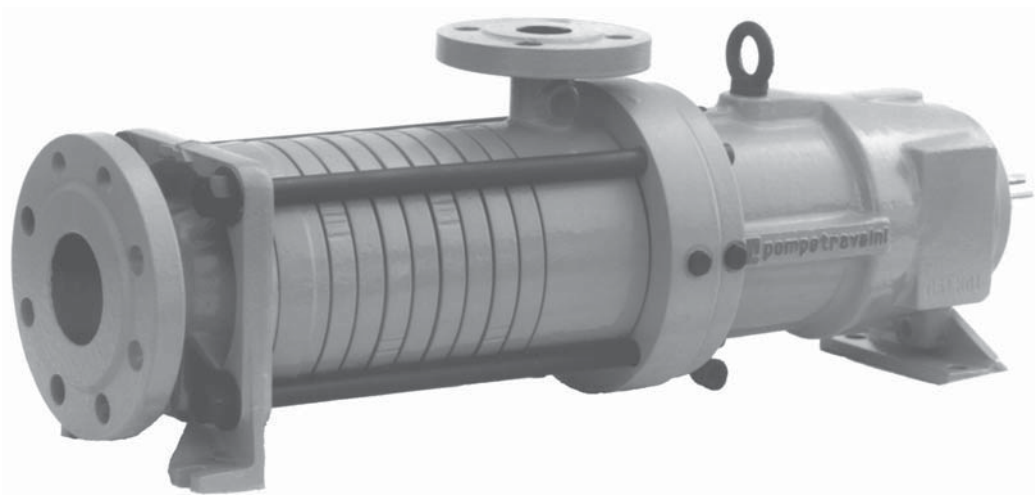

# INTRODUCTION

These instructions are for the maintenance personnel for maintenance and/or repair of the indicated pump series. Disassembly and assembly procedures should be carried out by qualified personnel. Prior to working on the pumps the maintenance person should be fully knowledgeable of the material outlined in this manual. Instructions relating to safety of operation, installation and maintenance will be found in the "OPERATING MANUAL FOR CENTRIFUGAL PUMPS" and in the "DISASSEMBLY AND ASSEMBLY INSTRUCTIONS FOR SELF-PRIMING MULTISTAGE CENTRIFUGAL PUMPS" which is usually supplied with the pump or it can be requested from your POMPETRAVAINI representative.



## CAUTION!

Pumps series TBK and TBAK create a high magnetic field. Personnel should take proper precautions if they are wearing pace-makers or if they are using instrumentation sensitive to magnetic fields.

The listed below minimum distances must be kept:

- When the magnetic rotor parts are disassembled:
  - users of pace-maker = 2 meters
  - floppy disk; magnetic cards, etc. = 1 meter
  
- When the magnetic rotor is mounted in the pump:
  - users of pace-maker = 1 meter
  - floppy disk; magnetic cards, etc. = 0,5 meter

Proper attire is necessary prior to beginning any work on the pumps. Therefore, for your safety, always wear safety hat, eyeglasses, gloves, shoes etc. and be sure to have proper tools necessary for the work to be done.

Do not force or subject pump or any of its components to sudden shocks or violent impact. Do not damage with markings or scratches the mechanical seal surface areas, the engagement surfaces and sealing areas. Do not damage gaskets, and O-Rings. Do not leave in the pump foreign matter such as screws, nuts, bolts, washers, rags, etc.

When requesting spare parts or technical information for the pump, always quote the pump model number and serial number which is printed on the pump nameplate: therefore it is recommended not to remove the pump nameplate or, in case this action will be necessary, write the serial number on the pump (for example on the flange).

Should additional information be required, please do not hesitate to contact POMPETRAVAINI or the closest representative. Should there be any difficulties in repairing the pump, it is recommended to send the pump for repair to POMPETRAVAINI or the local authorised representative.

POMPETRAVAINI will not and cannot be responsible for work done on the pump by the customer or non-authorised personnel.

NOTE: Pump parts are identified by item numbers (VDMA). Item numbers can be found in the parts list under chapter 10 and cross-referenced with the sectional drawings under chapter 11.

All drawings given in these instructions are only schematics and not certified.

## INDEX

- |  |   |
|--|---|
| 1 - Actions to be taken prior pump disassembly       | 6 - Complete disassembly for pumps series "TBAK"                        |
| 2 - "TBK" pump series disassembly to replace bushing | 7 - Internal magnet rotor disassembly for "TBK" and "TBAK" pumps series |
| 3 - "TBK" pump series bushing support assembly       | 8 - Assembly of "TBK" and "TBAK" pumps series                           |
| 4 - "TBK" and "TBAK" pump series support disassembly | 9 - Spare parts   |
| 5 - Complete disassembly for pumps series "TBK"      | 10 - Parts list   |
|  | 11 - Typical sectional drawings   |



The liquids and gas handled by the pumps and also their parts could be potentially dangerous for persons and environment: provide their eventual disposal in conformity with the laws into force and a proper environment management.



The present manual is not assigned for pumps subjected to the ATEX 94/9/CE directive. In case the pump is assigned in environments subjected to the application ATEX 99/92/CE directive or in case the pump is provided with a nameplate indicating the ATEX stamp, it is strictly forbidden proceed to start up the pumps but necessary to consult POMPETRAVAINI for clarifications.

For pumps subjected to the ATEX 94/9/CE directive it is available a dedicated integrative manual.

In preparing this manual, every possible effort has been made to help the customer and operator with the proper installation and operation of the pump. Should you find errors, misunderstandings or discrepancies please do not hesitate to bring them to our attention.

## 1 – ACTION TO BE TAKEN PRIOR PUMP DISASSEMBLY

Prior starting disassembly activities it is required:

- Shut down the pump following usual shut down procedures.
- Disconnect electric motor from electric supply in order to make sure that it may accidentally start up.
- Close valves installed on pump suction and discharge.
- Wait and make sure that temperature is equal to ambient temperature prior to start any activity.
- Unlock the drain plug in order to drain completely the spiral casing.  
Follow extra carefully this procedure in case pumped liquid is dangerous by contact or by inhalation.  
At this regard it is mandatory to be provided with proper safety wear.
- Disassembly pipes and auxiliary connections in case connected to pump.  
Remove coupling guard and, if present, spacer coupling.
- Loose the support foot VDMA 183 and, depending on needs, it is possible take away pump casing from piping and baseplate and/or remove the electric motor.

## 2 – “TBK” PUMP SERIES DISASSEMBLY TO REPLACE BUSHING

Loosen screws VDMA 901 and extract the bushing support VDMA 355 and its bushing VDMA 310 or 310.3 (in function if pump execution is /1 or /2) by means, if necessary, of the same screws as extractors in the threaded holes available in the support self. Later on, by means of a suitable extractor, extract the bushing support (see fig. 1 or 2).

In case of execution /2 also check the wear of ceramic coated bushing VDMA 521 and if necessary replace it loosening the screw VDMA 914.5 and removing the washer VDMA 554.

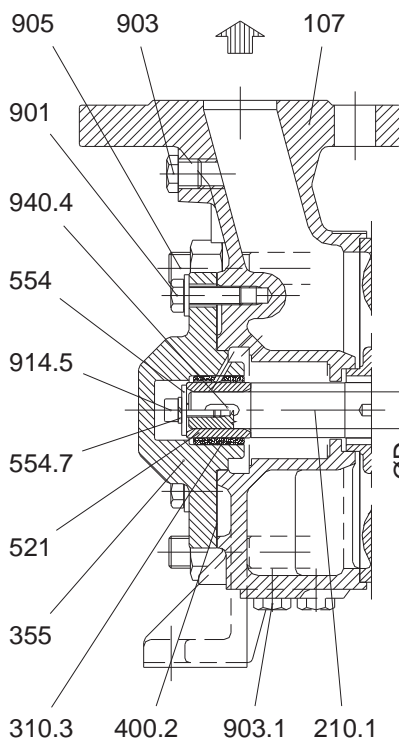

Fig. 1 – Pumps series TBK/2

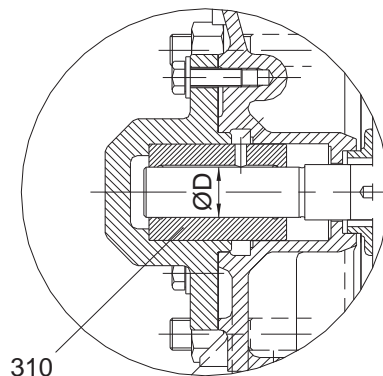

Fig. 2 – Pumps series TBK/1

## 3 – “TBK” PUMP SERIES BUSHING SUPPORT ASSEMBLY

Check wear of bushing VDMA 310 or 310.3 (in function of execution /1 or /2) and, if necessary, replace it with a spare one: check the bushing internal diameter is the right one for pump type indicated in object (see fig. 1 or 2 and tab. 1), then press it in the bushing support VDMA 355.

For execution /1 drill in the bushing 3 radial holes  $\varnothing 5$  mm at  $120^\circ$ , having care that one hole is located in upper position.

For execution /2 drill in the bushing 1 crossing hole  $\varnothing 3$  mm located in upper position in correspondence of the hole present in the bushing support VDMA 355.

After having located the gasket VDMA 400.2, assembly the bushing support on the discharge casing VDMA 107 and tight the screws VDMA 901.

Tab. 1 - Dimensions of bushings (VDMA 310 or 310.3) internal diameters already pressed in bushing support VDMA 355 (see fig. 1 or 2)

PUMPS SERIES	Construction /2		Construction /1	
	ØD	VDMA 310.3	ØD	VDMA 310
TBK 200	---	---	16 D7	+0,068 +0,050
TBK 290 ÷ 310	24 E8	+0,073 +0,040	22 D7	+0,086 +0,065
TBK 400	30 E8	---	---	---
TBK 500	---	---	28 D7	+0,086 +0,065
TBK 650	30 E8	+0,073 +0,040	---	---

## 4 - "TBK" and "TBAK" PUMP SERIES SUPPORT DISASSEMBLY

(See fig. 5 and typical sectional drawings under chapter 11).

Remove stud nuts VDMA 902 and separate the support VDMA 330 from casing cover VDAM 161 overcoming the magnets attraction force avoiding to damage the external rotor magnets VDMA 818.2.

To disassembly the external magnetic rotor with small size dragging (sealing container  $\varnothing 75$ , see fig. 6 and 10) is necessary to remove the adaptor ring VDMA 502 loosening the grub screw VDMA 904.

Loosen screw VDMA 900.1 and remove the junk ring VDMA 550.1.

Extract then the fly wheel VDMA 132 with the external magnetic rotor VDMA 818.2.

Remove the half elastic coupling from pump drive end and, unscrewing the screws VDMA 914.4, remove the external bearing cover VDMA 360.1, the elastic ring VDMA 935 and circlip VDMA 932.1.

Loosen screws VDMA 900 and extract the internal bearing cover VDMA 360.2.

Apply now a strong pressure on the primary shaft VDMA 210 drive end to extract the bearing VDMA 320 and remove the same shaft with bearing VDMA 320.1 from the support VDMA 330.

Remove circlip VDMA 932 and if necessary remove from shaft also bearing VDMA 320.1.

Verify that all parts are undamaged and wear or tear scratches are not present: if necessary replace those parts with original spare parts before starting assembly, executing each step reverse to disassembly steps.

## 5 - COMPLETE DISASSEMBLY FOR PUMPS SERIES "TBK"

Complete pump disassembly becomes necessary if, for example, the pump does not perform as expected due to an excessive wear of impellers VDMA 230 and/or suction and discharge elements VDMA 109 and 114.

Replacing or machining the worn-out parts will be a question of economics and /or time available to complete the repair.

This chapter will consider the disassembly of a pump without non-drive end sleeve bearing housing and drive end bearing and mechanical seal housing (see fig. 3): disassembly and assembly of these components have been addressed in chapters 2 – 3 – 4.

NOTE: where the mechanic is not familiar with the pump, it is advisable to draw a reference line along the pump. Mark each part with its location, rotation and assembly sequence; however the main components are already marked at the external upper part with reference logs to provide the proper position (see the attached "Disassembly and assembly instructions for self-priming multistage centrifugal pumps").

Disassembly work should be carried out with proper tools and using suitable disassembly sequence to prevent further damage to the pump parts.

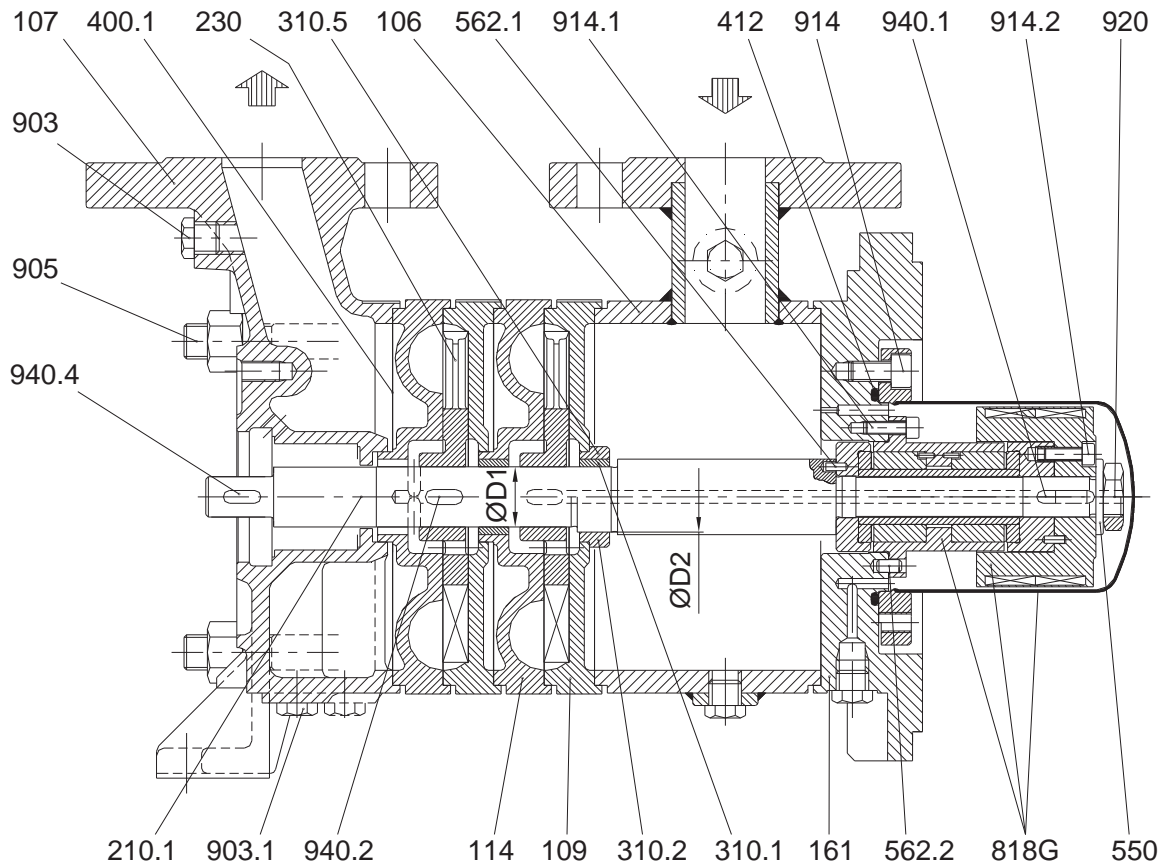

Fig. 3  
Pumps series TBK

Loosen and remove the tie-bolts VDMA 905, place the pump in vertical position onto a suitable base with the discharge casing VDMA 107 on the top.

Remove once for all the tie-bolts (VDMA 905) nuts and washers and loosen the tie-bolts from the casing cover VDMA 161. Remove the discharge casing VDMA 107 and its gasket VDMA 400.1, the discharge element VDMA 114 and its gasket, the open impeller VDMA 230, the key VDMA 940.2 the suction element VDMA 109 and its gasket. Go on following the same sequence as many times as is the number of stages of the pump. Remove the suction casing VDMA 106 and its gasket.

Take precautions not the damage the shaft VDMA 210.1 and place it in a bench vice vertically and with the drive side upward in order to disassemble the internal magnetic coupling assembly (see chapter 7).

## 6 - COMPLETE DISASSEMBLY FOR PUMPS SERIES "TBAK"

Complete pump disassembly becomes necessary if, for example, the pump does not perform as expected due to an excessive wear of impellers VDMA 230 and/or suction and discharge elements VDMA 109 and 114.

Replacing or machining the worn-out parts will be a question of economics and /or time available to complete the repair. This chapter will consider the disassembly of a pump without drive end bearing and mechanical seal housing (see fig. 4): disassembly and assembly of this component have been addressed in chapter 4.

NOTE: where the mechanic is not familiar with the pump, it is advisable to draw a reference line along the pump. Mark each part with its location, rotation and assembly sequence; however the main components are already marked at the external upper part with reference logs to provide the proper position (see the attached "Disassembly and assembly instructions for self-priming multistage centrifugal pumps").

Disassembly work should be carried out with proper tools and using suitable disassembly sequence to prevent further damage to the pump parts.

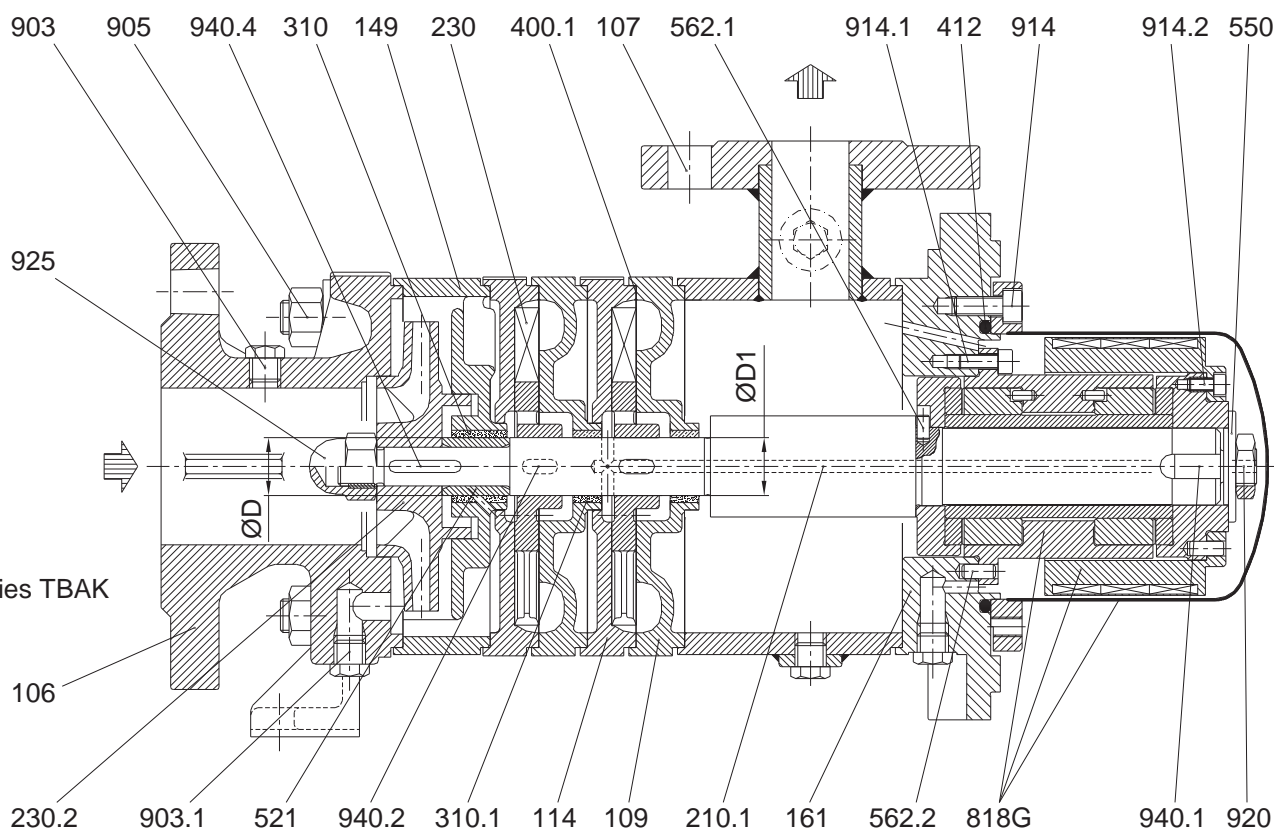

Fig. 4  
Pumps series TBAK

Loosen and remove the tie-bolts VDMA 905, place the pump in vertical position onto a suitable base with the suction casing VDMA 106 on the top.

Remove once for all the tie-bolts (VDMA 905) nuts and washers and loosen the tie-bolts from the casing cover VDMA 161.

Remove the suction casing VDMA 106 and its gasket VDMA 400.1.

Loosen the impeller nut VDMA 925 (pay attention to the left-handed threading) and remove the centrifugal impeller VDMA 230.2.

Remove the diffuser VDMA 149, its gasket and its sleeve bearing VDMA 310.

Remove the shaft VDMA 210.1 the spacer sleeve VDMA 521 and the key VDMA 940.4.

Remove the suction element VDMA 114 and its gasket VDMA 400.1, remove the open impeller VDMA 230, the key VDMA 940.2, the discharge element VDMA 109 and its gasket. Go on following the same sequence as many times as is the number of stages of the pump. Remove the discharge casing VDMA 107 and its gasket.

Take precautions not the damage the shaft VDMA 210.1 and place it in a bench vice vertically and with the drive side upward in order to disassemble the internal magnetic coupling assembly (see chapter 7).

A particular attention it is required during disassembly because silicon carbide inserts, that are very fragile, may break, chip off or going out of their seats.

Fig. 5  
Drawing of internal magnet rotor.  
(the dotted line shows external magnetic rotor component)

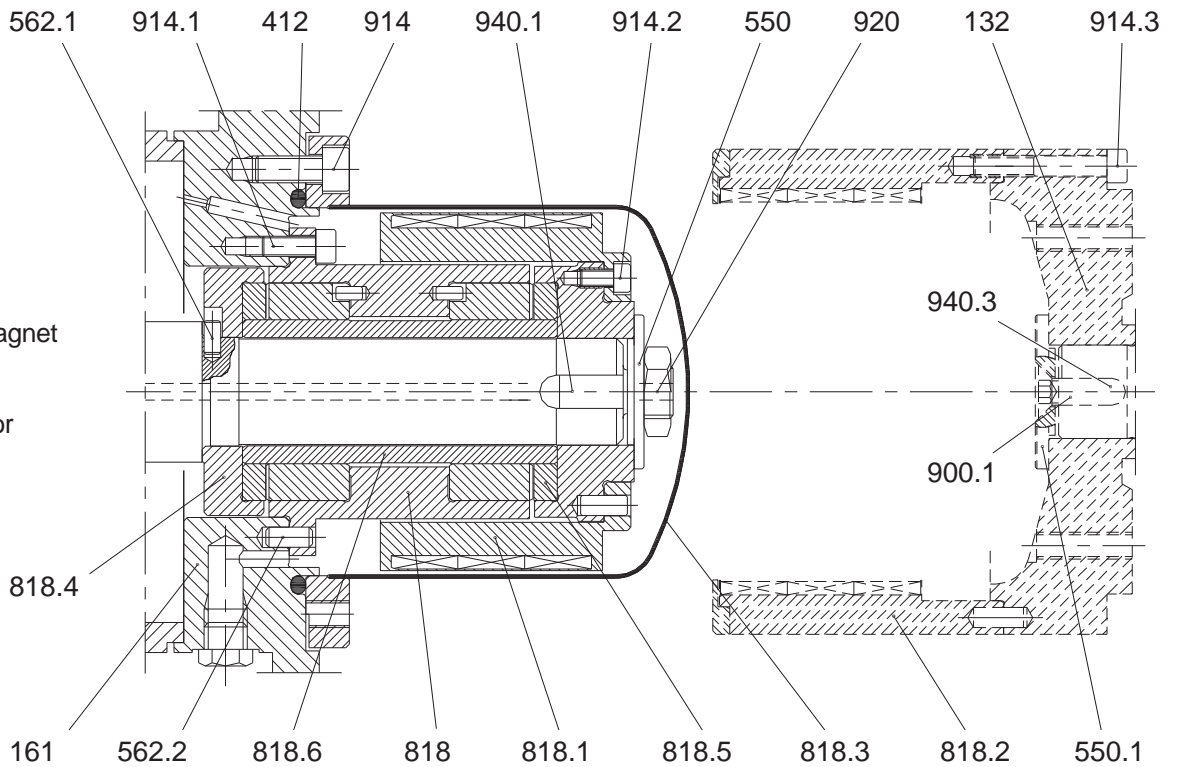

Undo VDMA 914 screws and remove the VDMA 813.3 cover and its sealing VDMA 412 O-Ring, undo the VDMA 920 nut and the VDMA 550 washer.

Remove the internal magnet rotor VDMA 818.1 with the external cover VDMA 818.5.

Remove the body VDMA 161 with the rotor support bush VDMA 818: If it is necessary to separate these two components, undo VDMA 914.1 screws.

Remove VDMA 940.1 shaft key, slip off the VDMA 818.6 rotor bush and the internal cover VDMA 818.4.

Look carefully the magnet bushes for scratches or beginning of seizure marks, eventually replace with original spare parts.

Clean all the components and proceed to assembly them reversing the step for the disassembly. The values for the torque wrench for the magnet screws are reported on the Tab. 2.

It is fundamental to lubricate all silicon carbide components that are in contact.

Tab. 2  
Maximum torque wrench setting for magnet component screws.

Screw Diameter	In contact with pumped liquid	Dry
M5	4 Nm	4,5 Nm
M6	7 Nm	7,5 Nm
M8	16 Nm	18 Nm
M10	32 Nm	
M12	55 Nm	
M16	65 Nm	

## 8 - ASSEMBLY OF "TBK" AND "TBAK" PUMPS SERIES

Check that all the pump components are in good condition, clean them with the proper clearing product.

If hydraulic components (VDMA 230 and 230.2 impellers, VDMA 109 e 114, elements.) could be re-installed but require machine tooling, please follow the included "Assembly and Disassembly of self-priming centrifugal pumps" instructions. In case of assembly of old components with new original spare part it is necessary to check full compatibility no matter if old components have been machined or not.

For suggested spare parts please read chapter 9.

About bush inner diameter please refer to tab 3 values considering pump type and bush VDMA number. Proceed to assembly the pump following the "Assembly and Disassembly of self-priming centrifugal pumps" instructions reversing the indicated steps of disassembly. Be careful about sequential steps and components reference point for assembly position.

Once pump assembly is completed, connect the pump to supporting assembly completed with external magnetic rotor, being aware of the strong attraction between the two parts.

Finally make the pump rotating by acting by hand on VDMA 210 drive shaft. Pump should rotate freely without generating any noise and or crackling.

Tab. 3

Bush internal diameter (VDMA 310 or 310.1 or 310.2) already pressed on VDMA 109 or 149 elements (see fig. 3 or 4)

PUMPS SERIES	ØD VDMA 310		ØD1 VDMA 310.1		ØD2 VDMA 310.2	
	TBK & TBAK 200	---	---	18 B9	+0,212 +0,160	18
TBK & TBAK 290 ÷ 310	24 E8	+0,073 +0,040	24 B9	28		
TBK & TBAK 400	30 E8		30 B9	---		
TBK & TBAK 500		32 B9	+0,232	32		
TBK & TBAK 650		36 B9	+0,170	---		

## 9 - SPARE PARTS

When ordering the pump it is good practice to also order the necessary spare parts, especially when there are no stand-by pumps in the installation. This will minimise unnecessary down times in the event of pump failure or routine maintenance. Following spare parts are suggested for each pump size:

1 or more	Impellers
1 or more	Suction plates
1 or more	Discharge plates
1	Shaft assembly
1	Bearing set
2	Sets gaskets
1	Set of bearing spacer rings

However for proper parts management, consult the VDMA 24296 standard that recommends the quantity of spare parts to be stocked in relation to the number of pumps installed.

On the pump nameplate are printed the pump model, the year of manufacture and the pump serial number: always provide this information when requesting spare parts.

Specify also the VDMA number of the required part, as seen on the pump sectional drawing (chapter 11) and parts list (chapter 10) for proper identification of spare parts.

We recommend the use of original spares: in case this is not respected, POMPETRAVAINI declines any responsibility for eventual damages caused by not original spare parts.

VDMA No.	DESCRIPTION
106	Suction casing
107	Discharge casing
109	Suction plate
114	Discharge plate
132	Fly-wheel
149	Centrifugal diffuser
161	Casing cover
183	Support foot
210	Primary shaft
210.1	Secondary shaft
230	Stellar impeller
230.2	Centrifugal impeller
310	Bearing
310.1	Plate bearing
310.3	Housing bearing
310.5	Bearing holder sleeve
320	Single row ball bearing
320.1	Single row ball bearing
330	Ball bearings housing
355	Bearing housing
360.1	External ball bearing cover
360.2	Internal ball bearing cover
400.1	Plate gasket
400.2	Bearing housing gasket
412	O-Ring
502	Reduction ring
521	Ceramic sleeve
550	Rotor bottom ring
550.1	Fly-wheel bottom ring
554	Shaft bottom ring

VDMA No.	DESCRIPTION
554.6	Elastic washer
554.7	Washer
562...	Pin
730	Elbow
731.8	Fitting
735	M.M. fitting
818	Rotor bearing housing
818.1	Internal magnetic rotor
818.2	External magnetic rotor
818.3	Sealing can
818.4	Internal cover
818.5	External cover
818.6	Rotor sleeve
818G	Magnetic coupling assembly
900...	Screw
900.5	Eyebolt
901...	Screw
902	Stud wit nut
903...	Plug
904	Grub screw
905	Tie-bolt with nuts and washers
914...	Screw
920	Nut
925	Cap nut
932...	Circlip
935	Elastic ring
940...	Key
STM	Thermometric probe





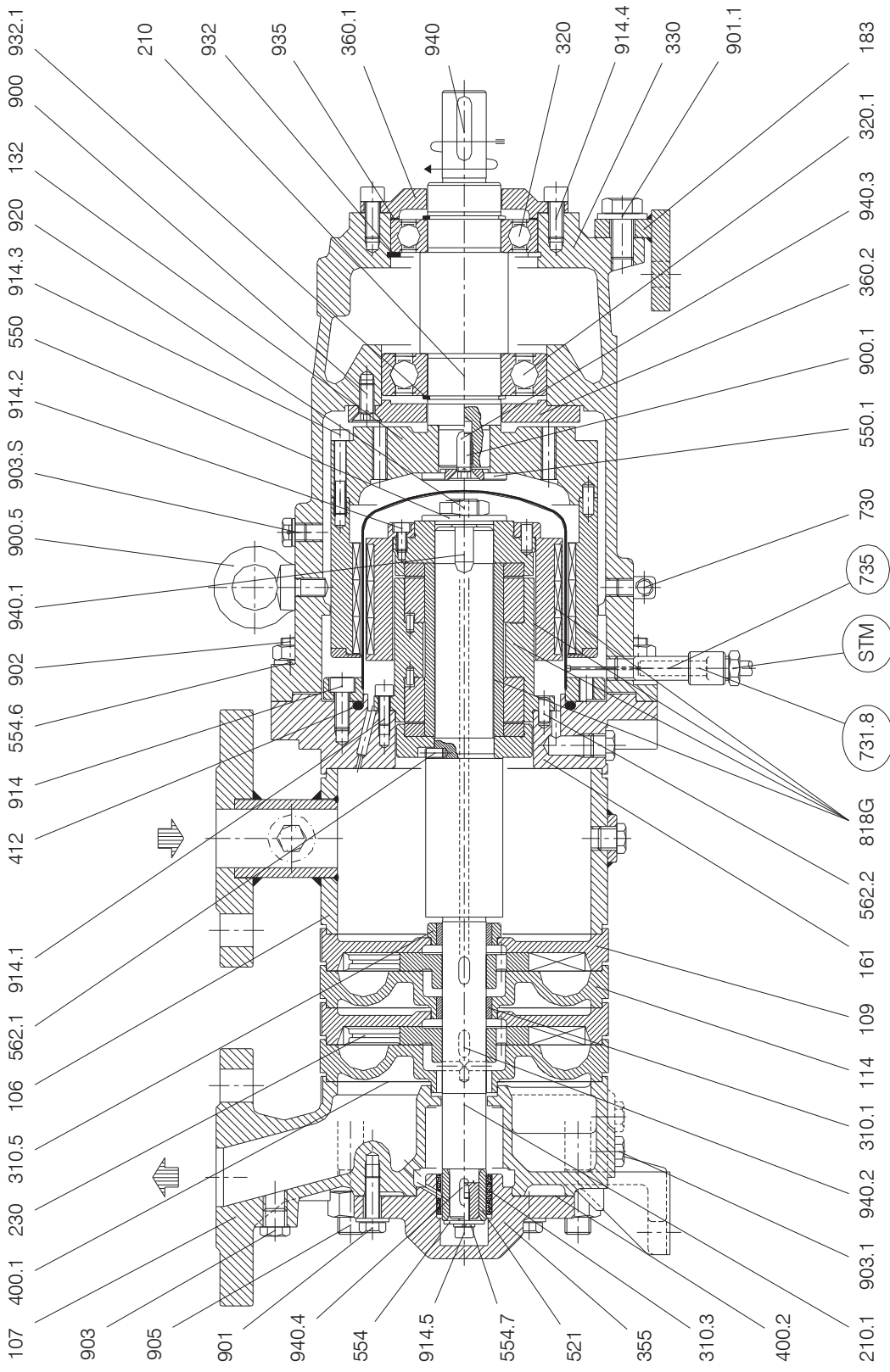

Fig. 8 - Pumps series TBK/2

With sealing can (VDMA 818G) Ø110 o 135

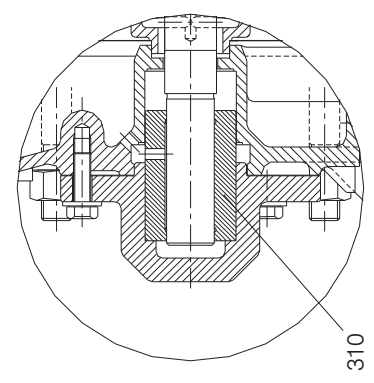

Fig. 9 - Pumps series TBK/1

○ Only for construction with Thermometric Probe

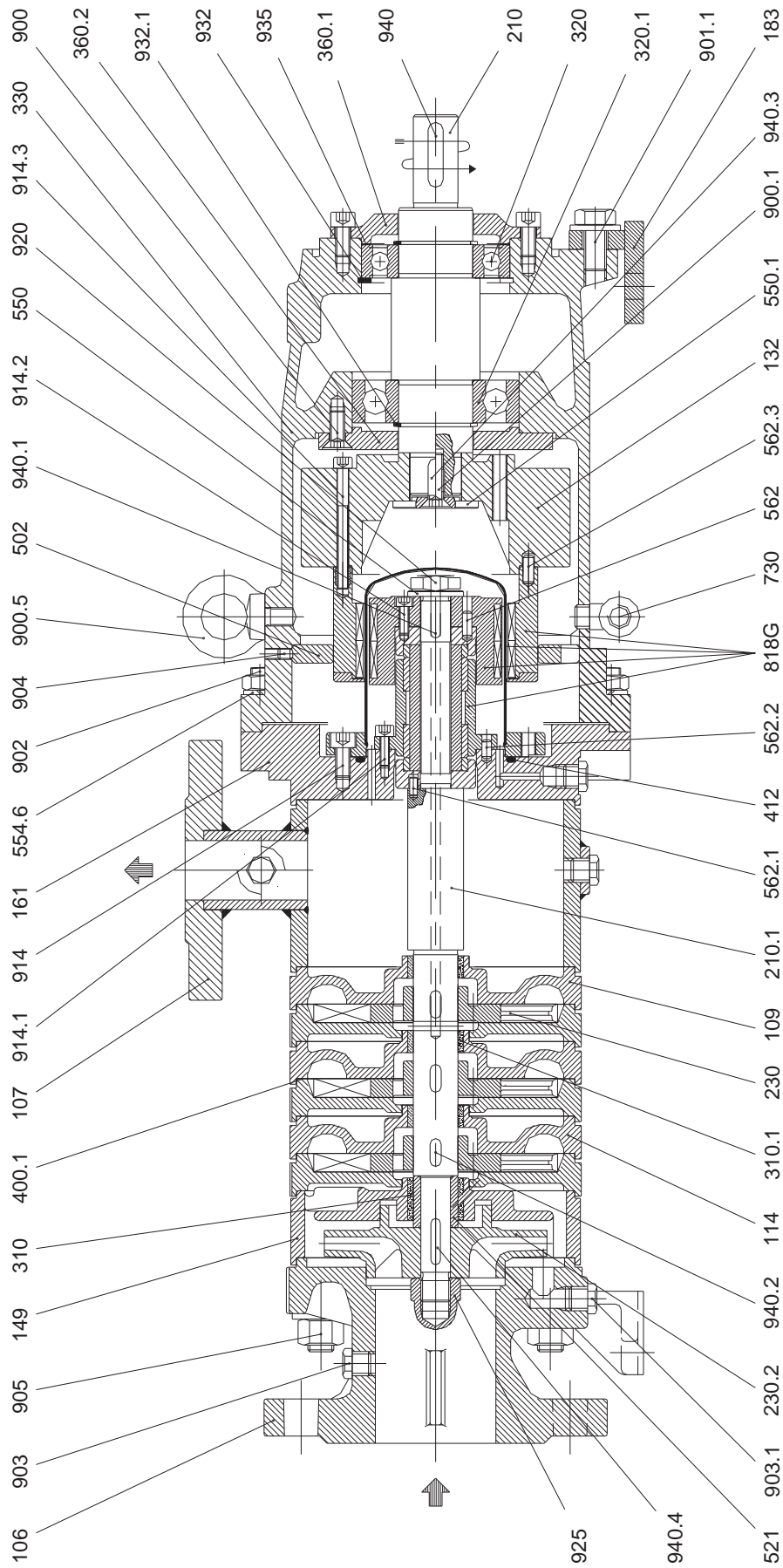

Fig. 10 - Pumps series TBAK  
With sealing can (VDMA 818G) Ø75

○ Only for construction with Thermometric Probe

**NOTES**

PUMP model .....	Serial Number .....	Computer Number .....	Year of manuf. .....
---------------------	------------------------	--------------------------	-------------------------

LIQUID handled .....	Capacity .....m <sup>3</sup> /h	Suction Pressure .....m	Discharge Press. .....m	Temperature .....°C
<input type="checkbox"/> Lethal <input type="checkbox"/> Toxic <input type="checkbox"/> Noxious <input type="checkbox"/> Corrosive <input type="checkbox"/> Irritant <input type="checkbox"/> Malodorous <input type="checkbox"/> .....				
<input type="checkbox"/> Clean <input type="checkbox"/> Dirty <input type="checkbox"/> With suspended parts		Spec. Gravity.....	Viscosity.....	PH.....

TOTAL WEIGHT  
.....KGs.

MAXIMUM DIMENSIONS

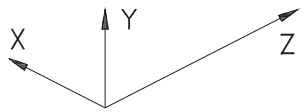

X = .....cm  
Y = .....cm  
Z = .....cm

NOISE (measured at 1 m)

Pressure = .....dB(A)  
Power = .....dB(A)

INSTALLATION

Inside    Outside  
 Explosive area    .....

SERVICE

Continuous    Intermittent  
 .....

MOTOR type / Frame .....	No Poles .....	No Revolutions .....RPM	Absorbed power .....Amp	Installed Power .....kW / .....HP
Frequency .....Hz	Supply .....Volt	Enclosure IP.....	Insulation class .....	Absorbed Power .....kW / .....HP

**COMMENTS**

---

---

---

---

---

---

---

---

---

---

NA4.SM.TBAK.GB00 / PRINTED IN ITALY  
Smontaggio TBK-TBAK Inglese

Continuing research of POMPETRAVAINI results in product improvements: therefore any specifications may be subject to change without notice.

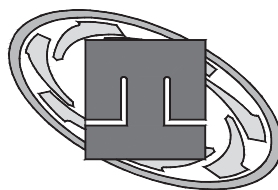
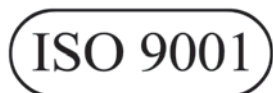

**pompetravaini** S.p.A.  
20022 CASTANO PRIMO (Milano) ITALY  
Via per Turbigo, 44 – Zona Industriale  
Tel. 0331 889000 – Fax 0331 889090  
www.pompetravaini.it